

HYBRID	 <p>WORLD CASHEW CONFERENCE</p>	Jointly organised by Cashewinformation.com &  <p>AEC-CI <small>ASSOCIATION DES EXPORTATEURS DE CACAÏCOTE D'IVOIRE</small></p>
	<p>JNEC-CI Journées Nationales des Exportateurs de Cajou de Côte d'Ivoire</p>	16-18 Feb, 2022 Radisson Blu Hotel Abidjan, Cote d'Ivoire



**CASHEW MACHINES VIETNAM (CMV) is the exclusive distributor
of THANH PHAT MECHANICAL TECHNOLOGY SERVICE TRADING**

OUR MISSION

- We are an international manufacturer of cashew processing machine which was founded in **2014**, located in Ho Chi Minh City, Vietnam.
- After many years of improvement, we looked into a system automatic (90-95%) cashew processing line to help businesses save labor costs, cut time, whole and piece-rate to ensure quality output and reduce the cost of productions.
- CMV is destined to become a solution provider that pioneers in the design and installation of new factories, upgrading small factories to improve technology, capacities from conception to realization of customer's products.
- We are proud to be a provider of master solutions for cashew processing machinery, technologies in Vietnam and other countries in the world.



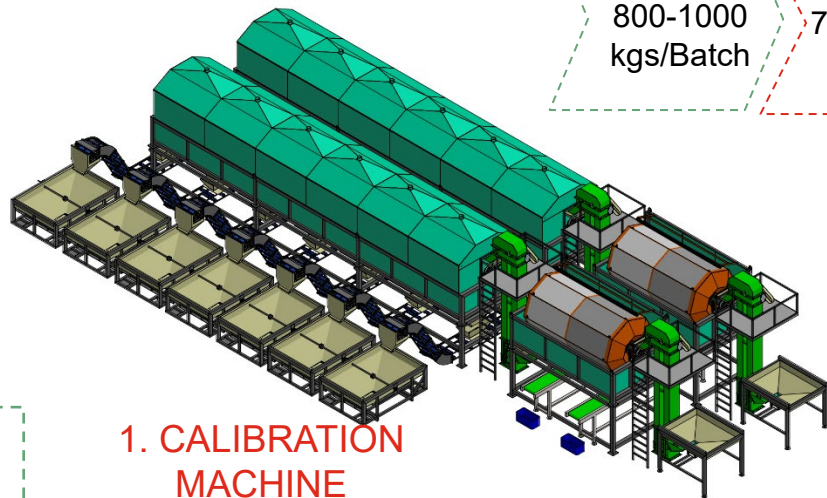

1. CALIBRATION MACHINE

- Capacity**
800-1000 kgs/Batch
- Dimension**
7.3 x 3.6 x 6.8 (m)
- Power Supply**
3 Kwh (3 phase 380v/50hz)
- Included**
Feeding elevator, cooling system

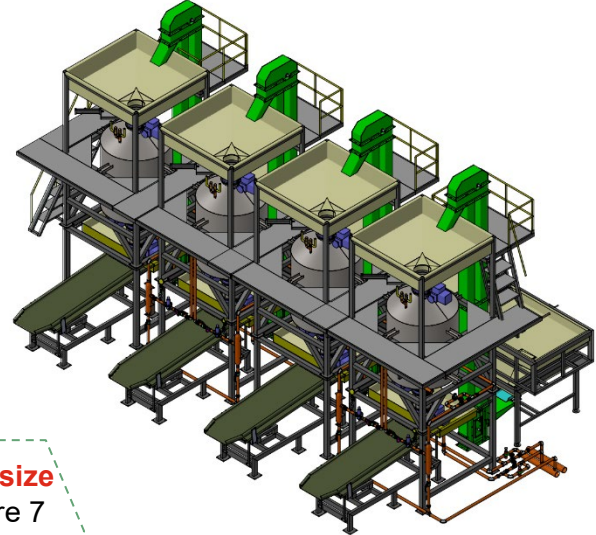

2. STEAMING MACHINE

- Capacity**
2000 kgs/hr
- Dimension**
15.0 x 1.5 x 2.5 (m)
- Power Supply**
8.25 Kwh (3 phase 380v/50hz)
- Included**
Feeding elevator, stone filter system
- Total of size**
There are 7 size separated

3. SHELLING MACHINE

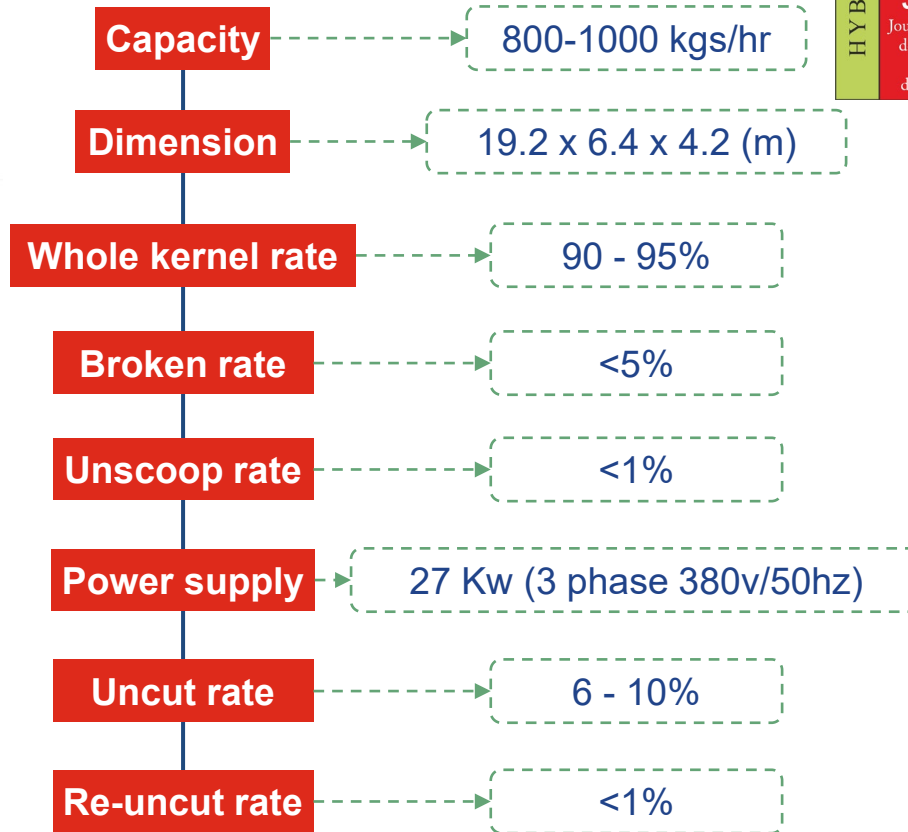
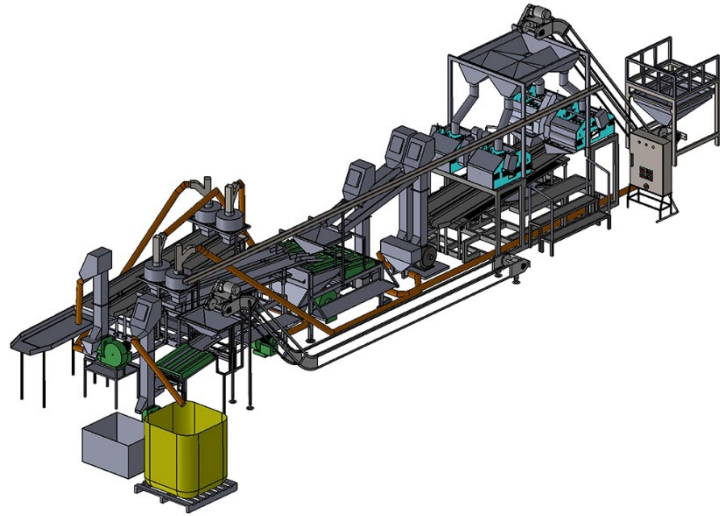

4. DRYER MACHINE

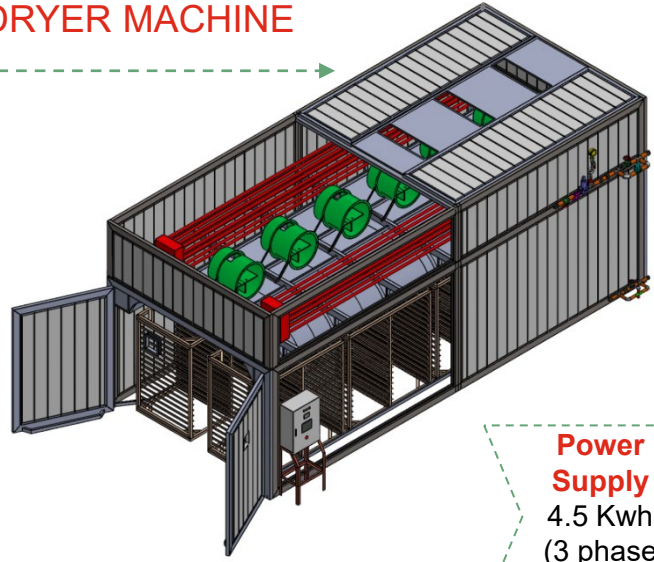

Capacity
2000
kgs/Batch

Dimension
7.0 x 3.0 x 2.8
(m)

Power Supply
4.5 Kwh
(3 phase
380v/50hz)

Drying time
10 – 14 hr /
batch

5. HUMIDIFICATION ROOM

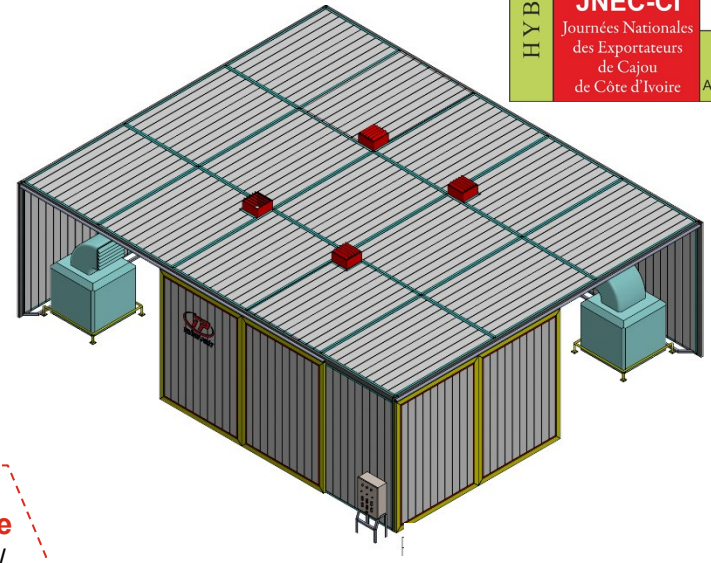

Dimension

9.0 x 7.0 x
3.0 (m)

Capacity

6000
kg/batch

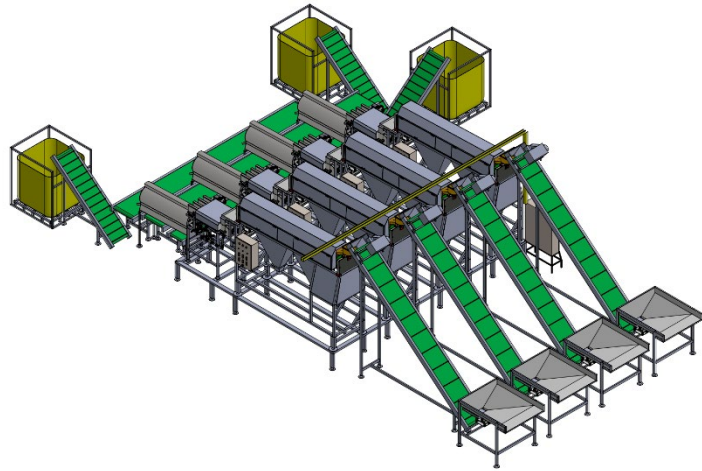

6. PEELING MACHINE

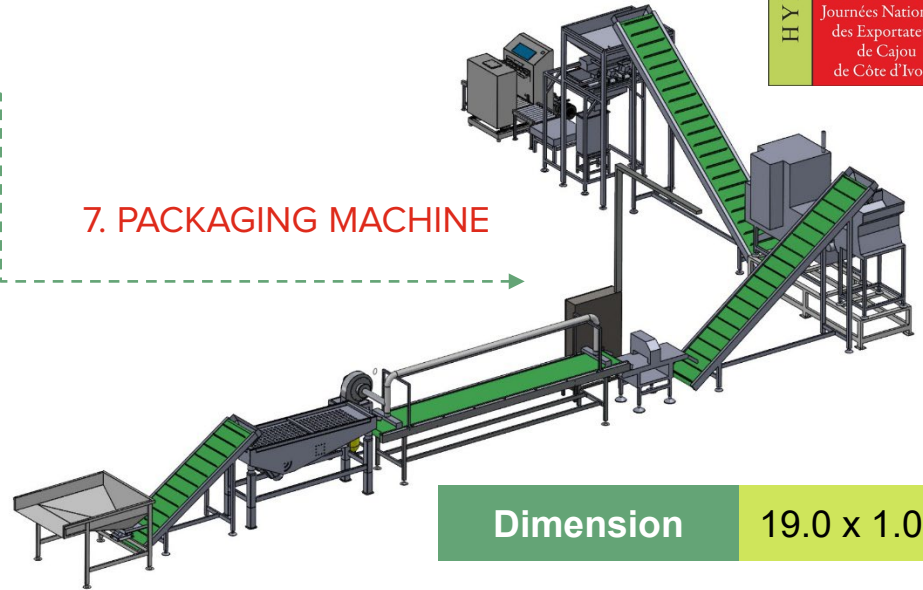

7. PACKAGING MACHINE

Dimension
11.1 x 1.2 x 3.2 (m)

Capacity
350 – 400 kgs/hr

Air compressor supply
55 Kw – 7 bars

Broken rate
5 - 10%

Power supply
4.5 Kwh (3 phase 380v/50hz)

Whole kernel peeled rate
First: 70 – 80%
Second: At least 90 -95%

Dimension 19.0 x 1.0 x 2.5 (m)

Capacity 60 – 80 packer / hr

Power supply 9 Kwh (3 phase 380v/50hz)



Thank you